

Bristol 1/40

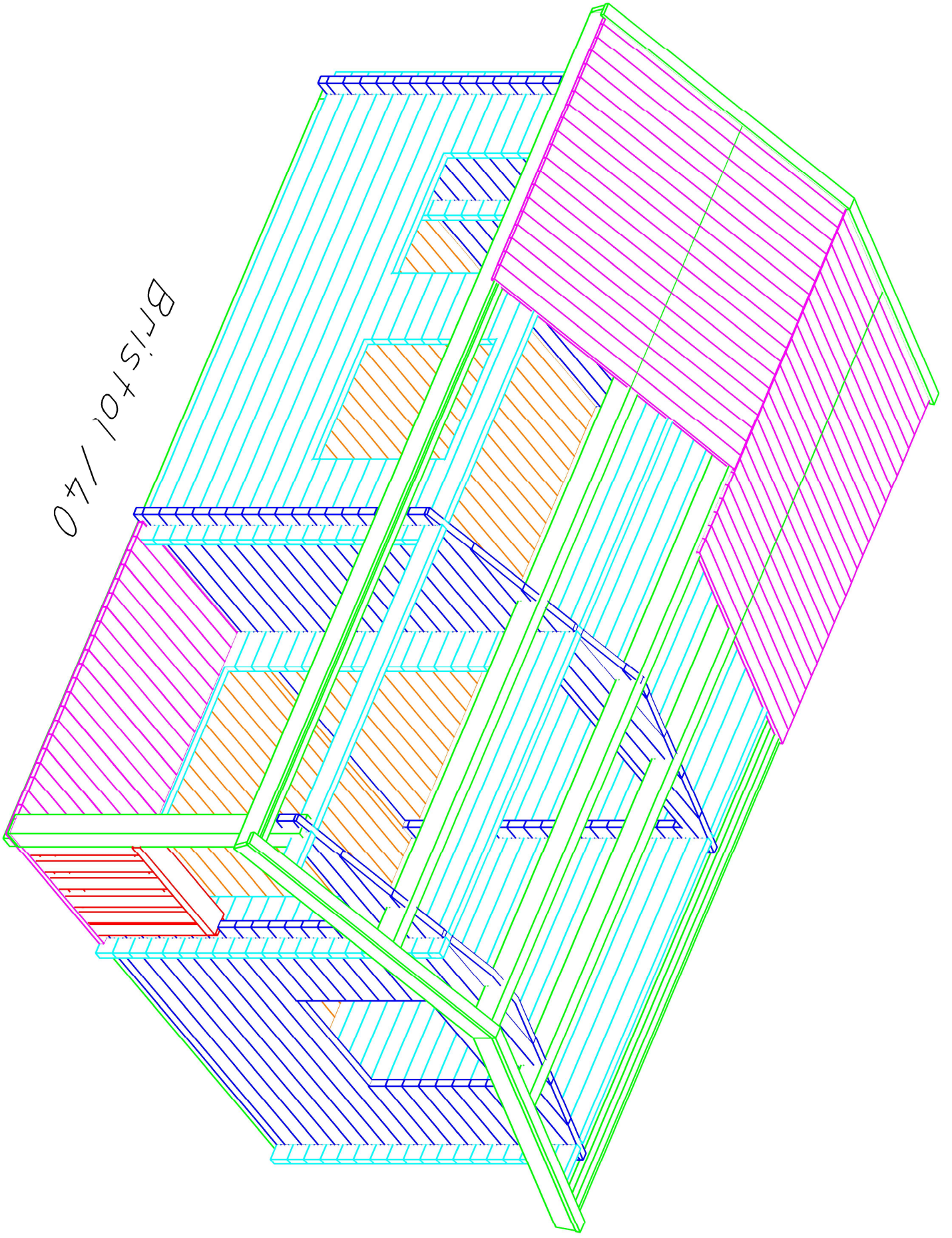

# Bristol/40

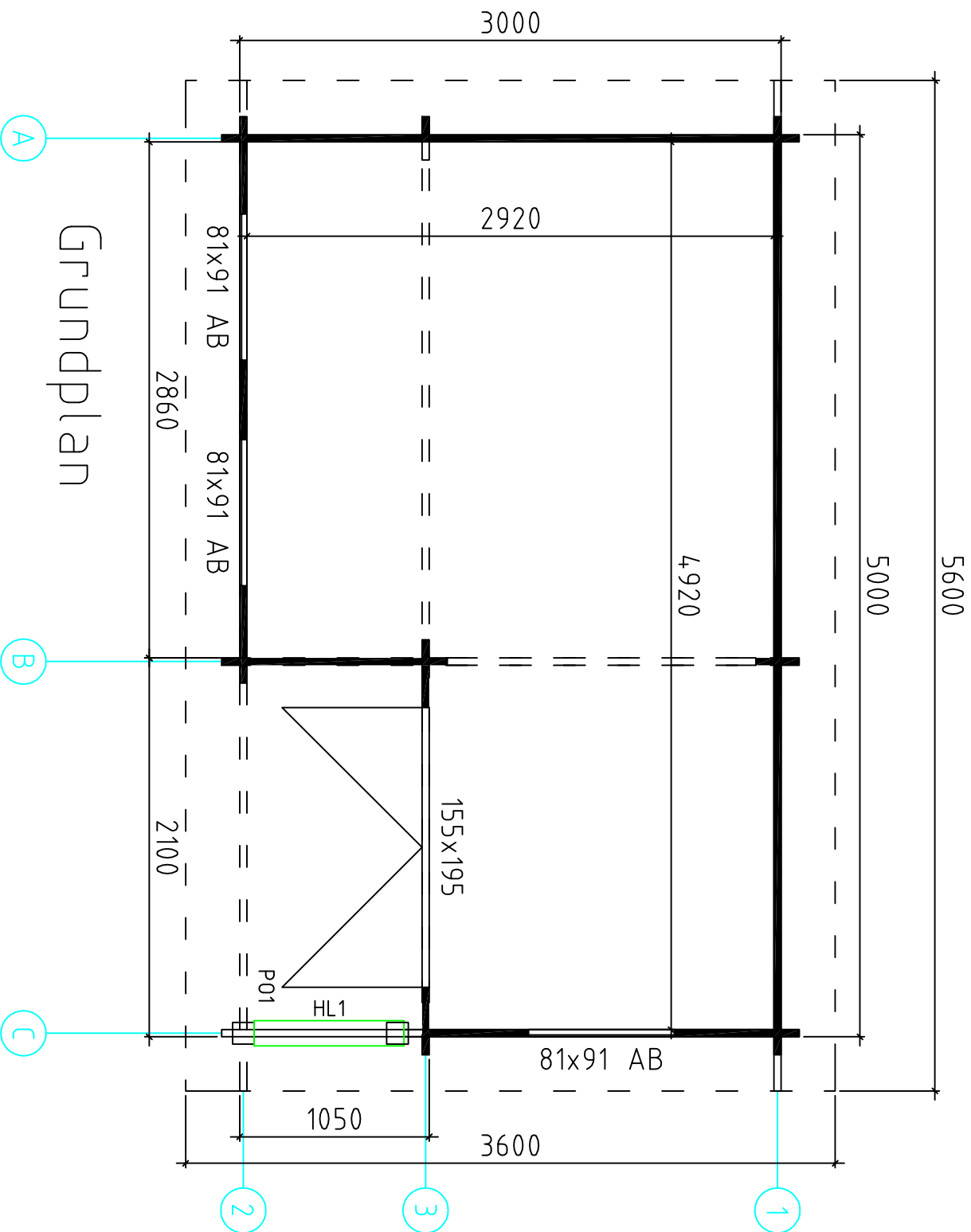

Grundplan

# Bristol/40

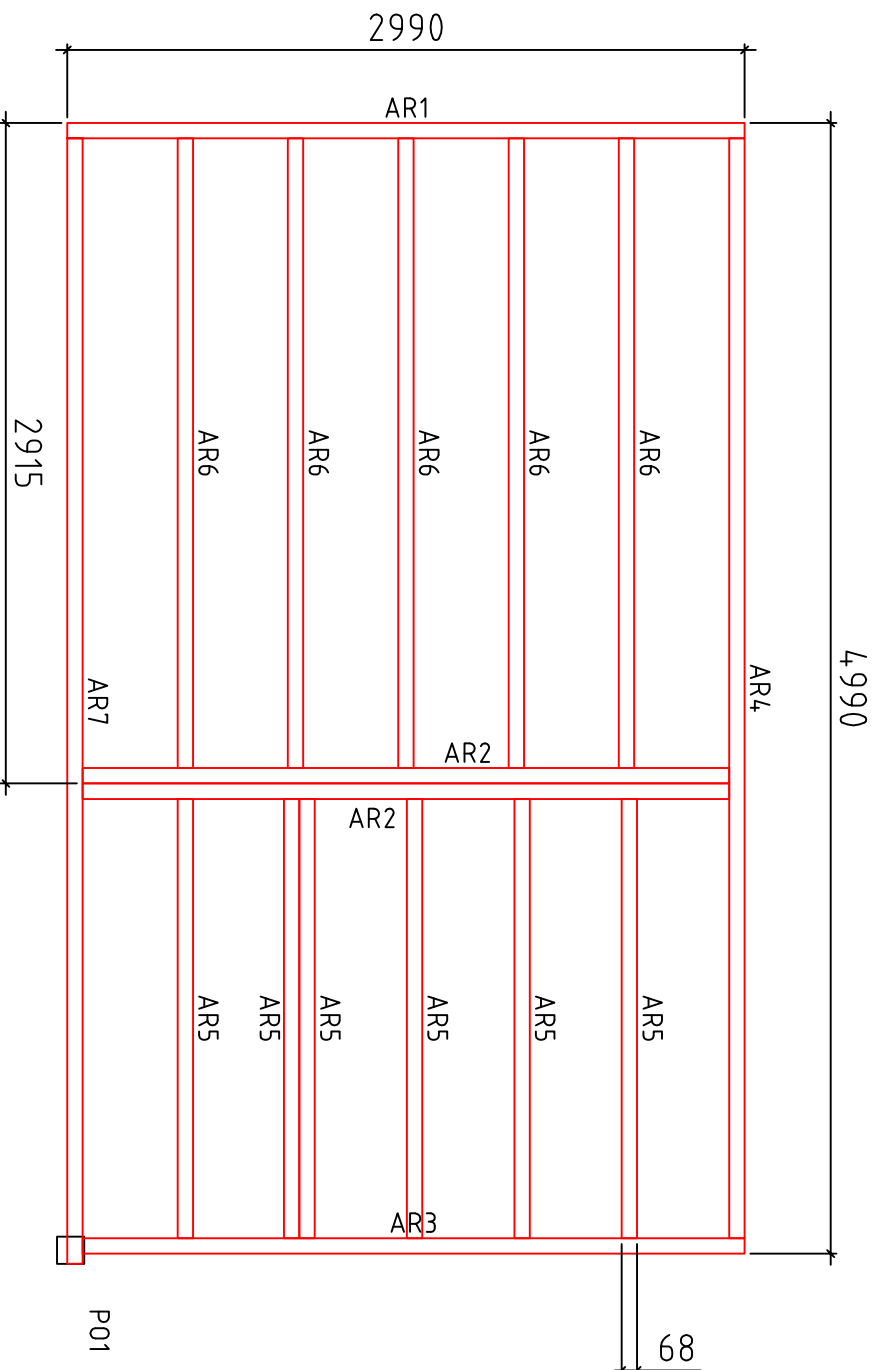

Fundamentbalken 68x44

Bristol/40

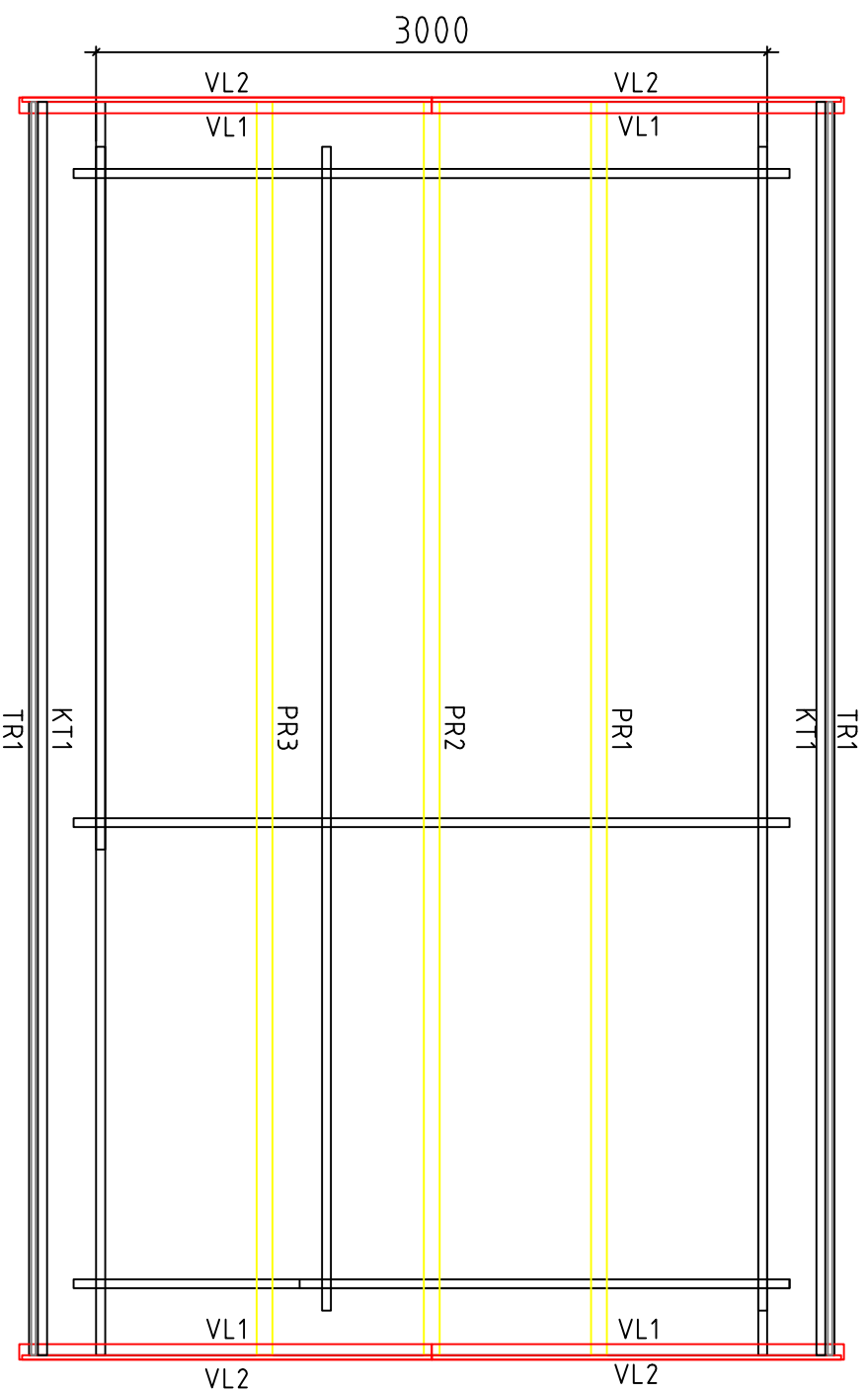

Traufenbretter TR  
Karniesenträger KT  
Giebelbretter VL

Dachbalken 70x140 PR

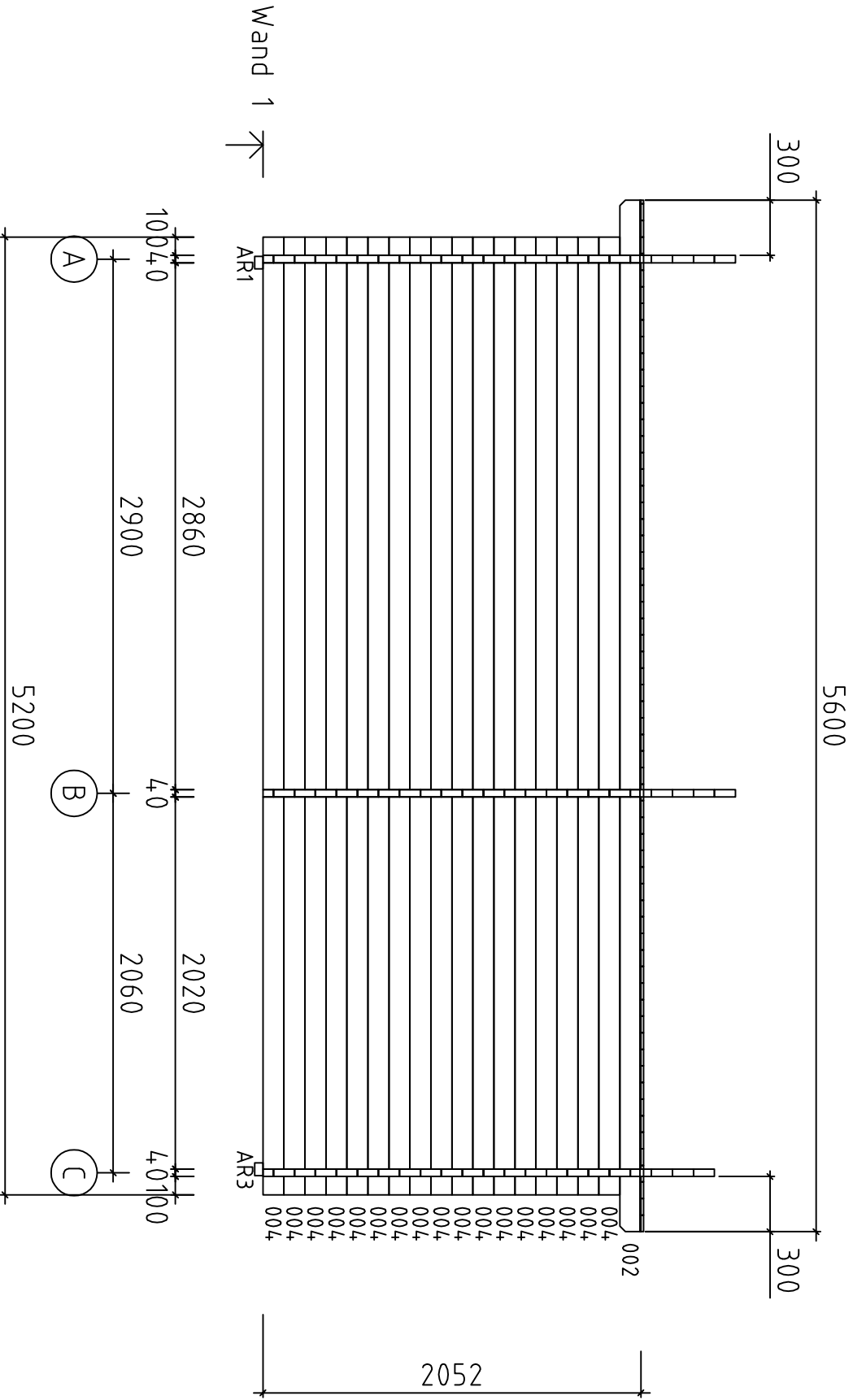

Bristol/40

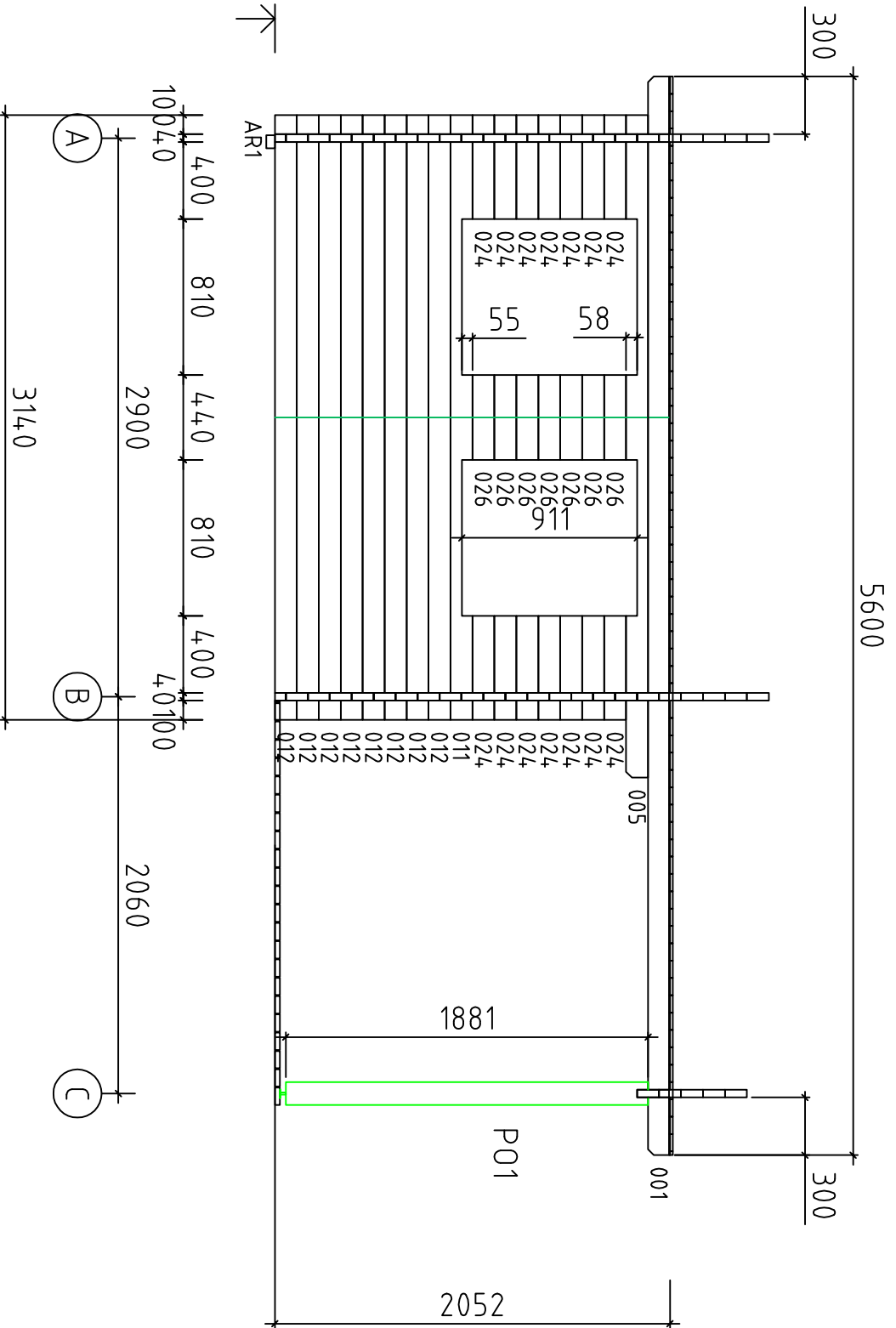

Bristol/40

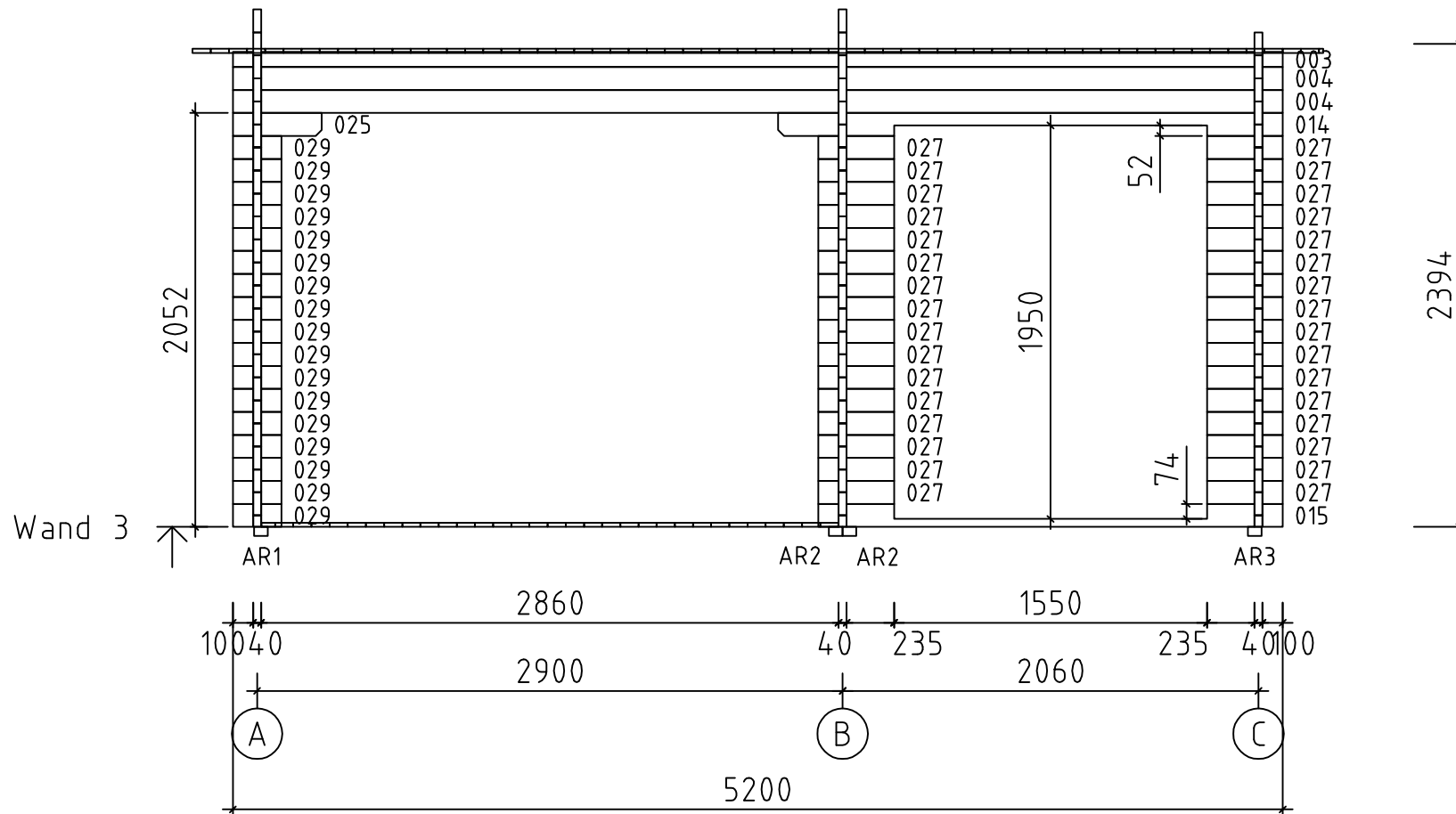

Bristol/40

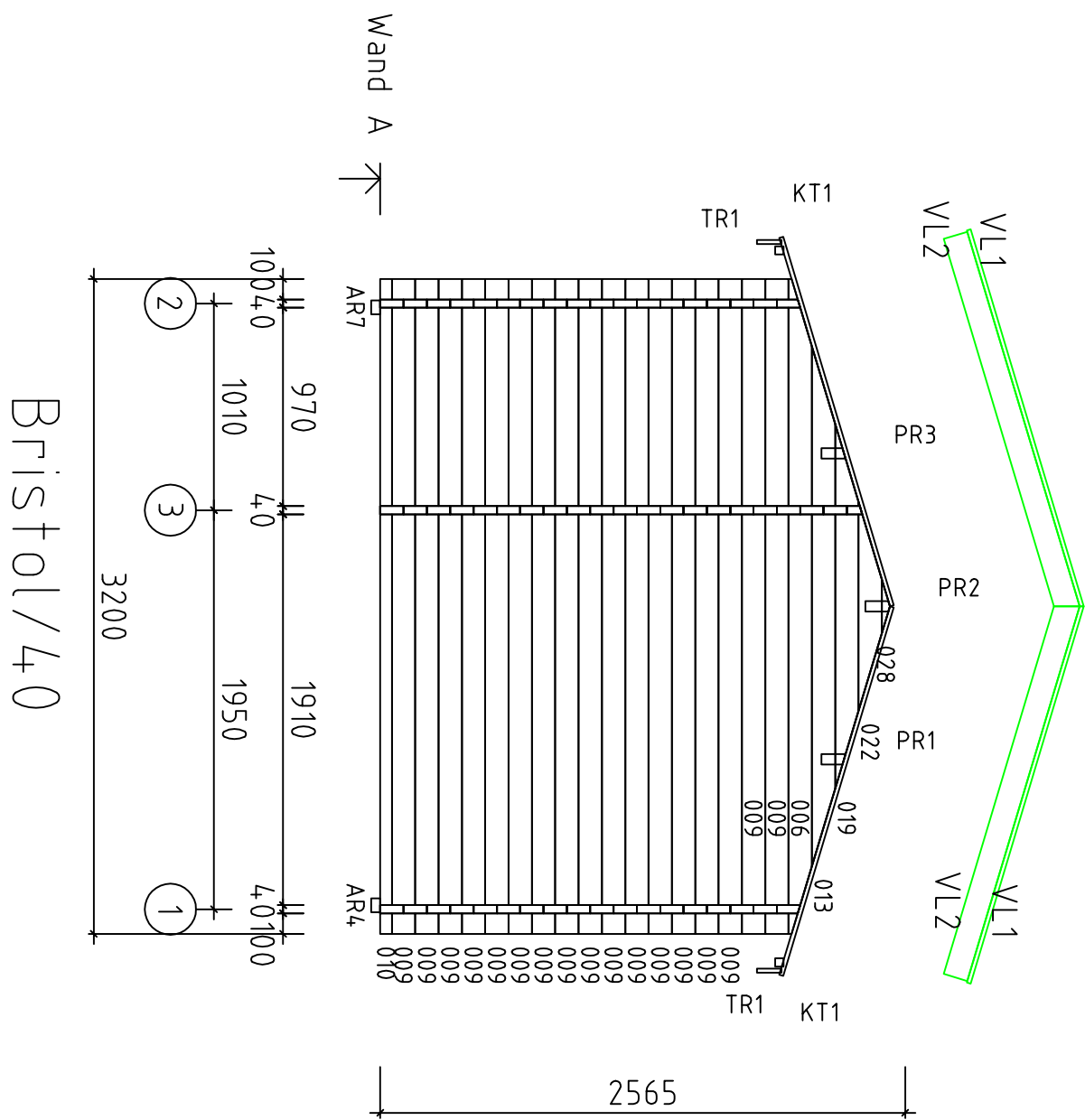

Wand A →

Bristol/40



# Bristol/40

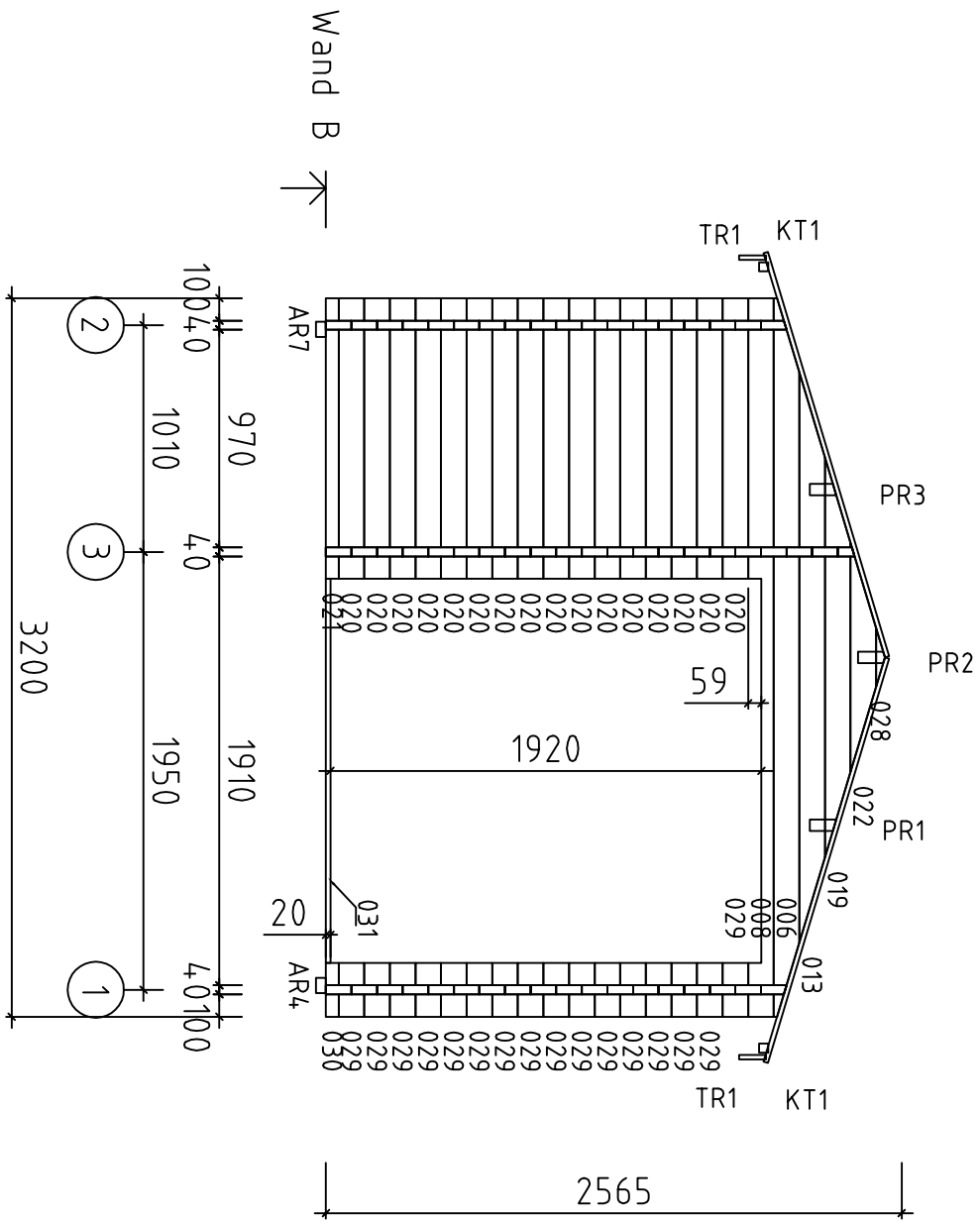

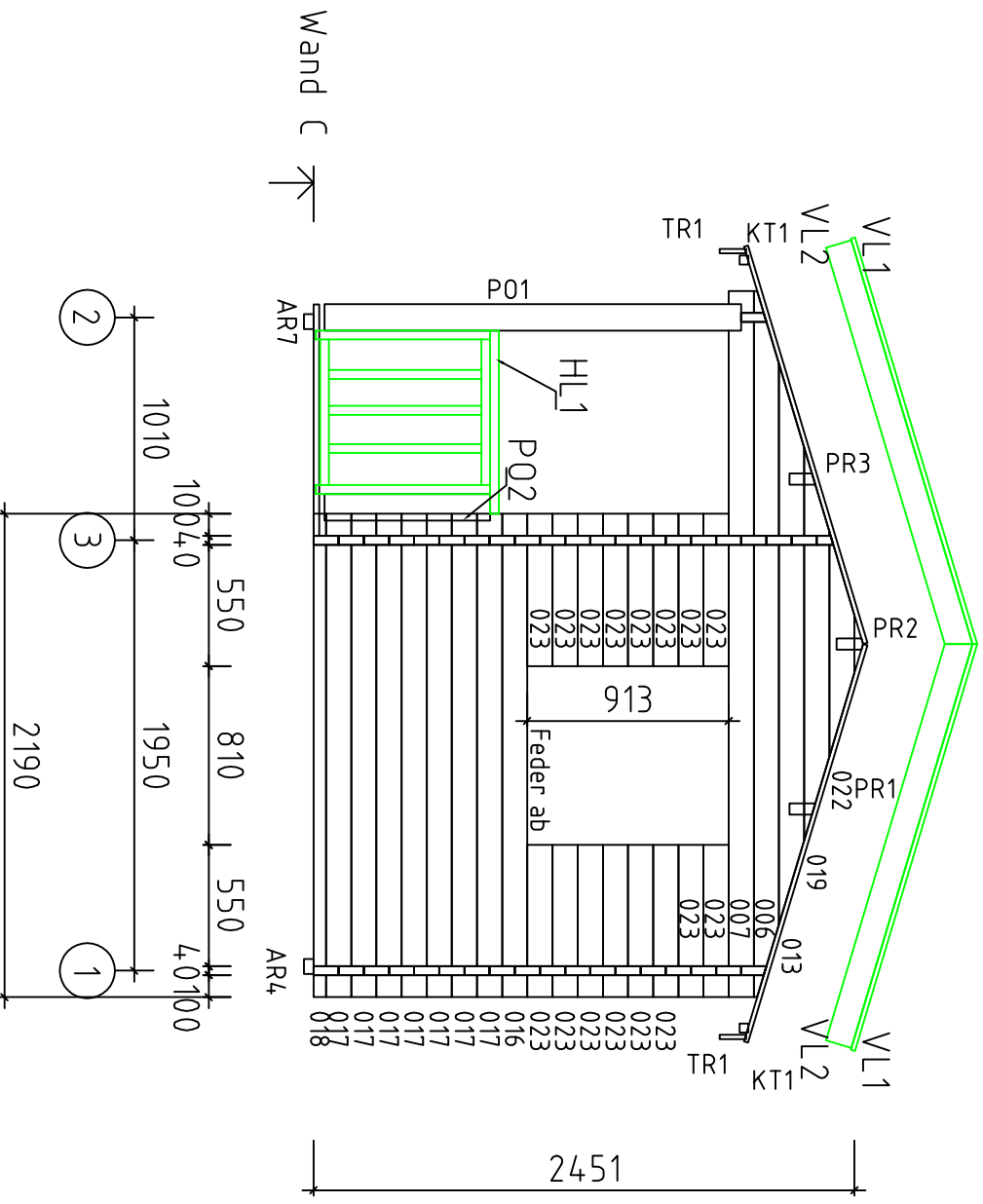

Bristol/40



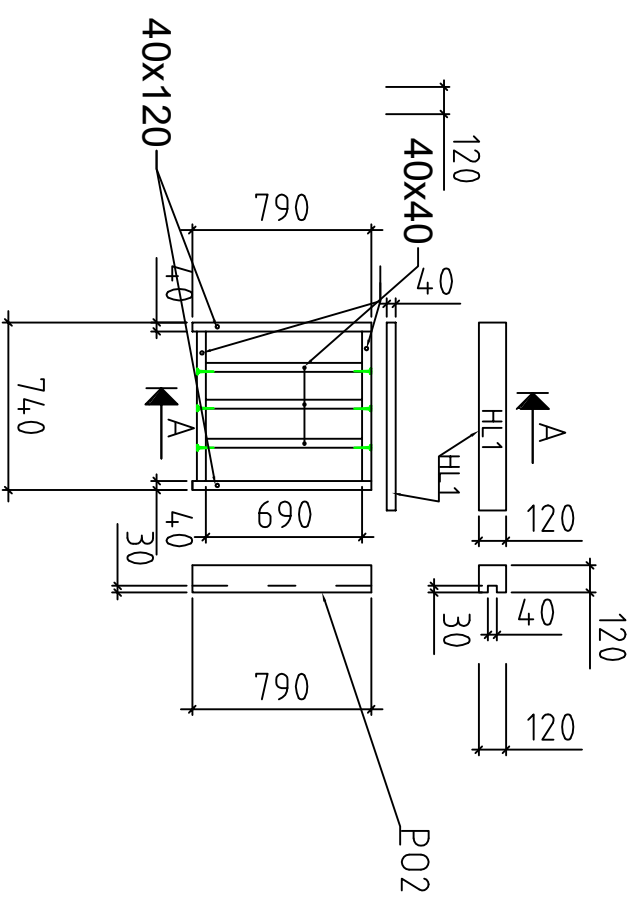



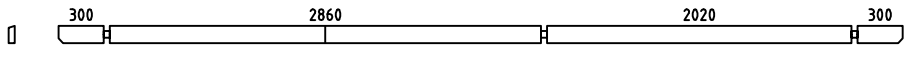
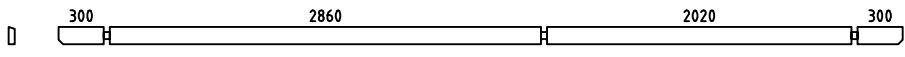
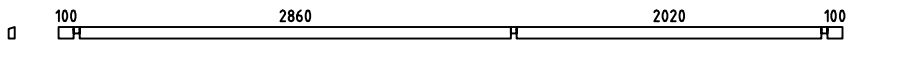
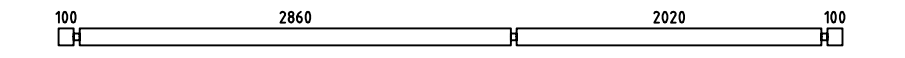
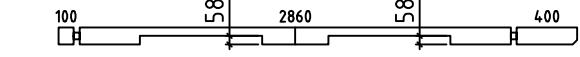
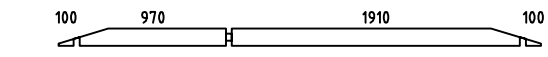
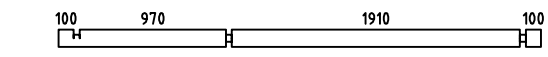
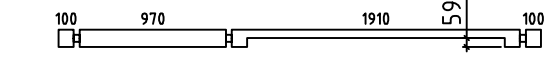
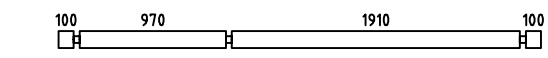
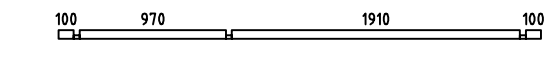
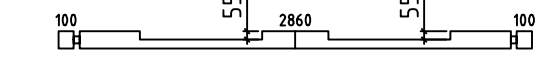
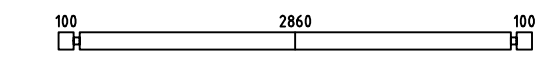
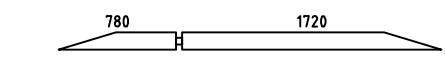
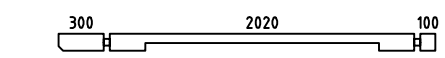
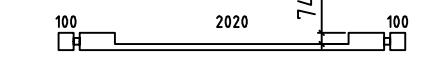
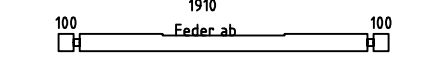
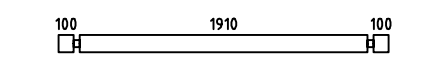
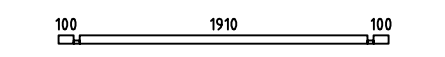
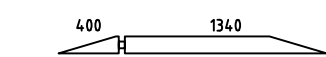
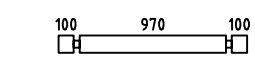
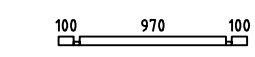
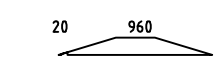
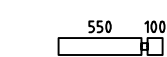
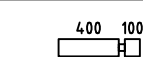
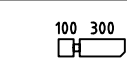





# Barrieren

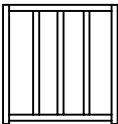

Bristol/40

Pos	Bristol/40	Arv	Profiil (mm)	Pikkus (mm)
001		1	40x114	5600
002		1	40x114	5600
003		1	40x75	5200
004		19	40x114	5200
005		1	40x114	3440
006		3	40x114	3200
007		1	40x114	3200
008		1	40x114	3200
009		17	40x114	3200
010		1	40x57	3200
011		1	40x114	3140
012		8	40x114	3140
013		3	40x114	2540
014		1	40x114	2500
015		1	40x114	2300
016		1	40x114	2190
017		7	40x114	2190
018		1	40x57	2190
019		3	40x114	1780
020		16	40x114	1250
021		1	40x57	1250
022		3	40x114	1020
023		16	40x114	690
024		14	40x114	540
025		1	40x114	440

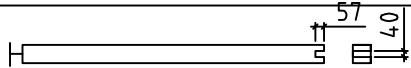
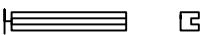
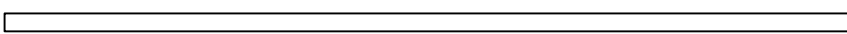

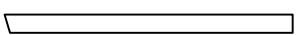
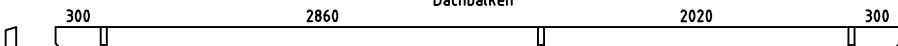
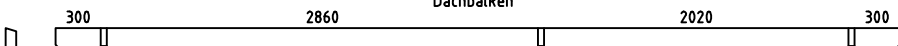
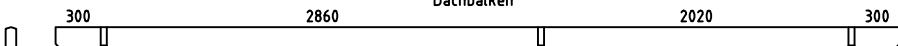
Pos	Bristol/40	Arv	Profiil (mm)	Pikkus (mm)
AR7	Fundamentbalken 	1	68x44	4967
AR4	Fundamentbalken 	1	68x44	4854
AR1	Fundamentbalken 	1	68x44	2990
AR3	Fundamentbalken 	1	68x44	2922
AR2	Fundamentbalken 	2	68x44	2854
AR6	Fundamentbalken 	5	68x44	2779
AR5	Fundamentbalken 	6	68x44	1939
HL1	Handlauf 	1	120x40	830
	Barrieren 	1		
KT1	Karnisen träger 	2	40x40	5600
P01	Pfosten 	1	120x120	1880
P02	Pfosten 	1	40x100	790
TR1		2	20x120	5600
VL1	Giebelbretter 	4	70x20	1920
VL2	Giebelbretter 	4	20x120	1900
PR3	Dachbalken 	1	70x140	5600
PR1	Dachbalken 	1	70x140	5600
PR2	Dachbalken 	1	70x140	5600

